



4L Commercial Pail with Integral Plastic Handle

222 series

Mold Number(s): R-226

A 4L tapered pail with integral plastic handle that is optimized for food service and household product applications. A large printable area allows for high impact graphics for a greater shelf presence. Both pail and molded on handle are injection molded from high density polyethylene resin, making this all plastic package perfect disposal or recycling. The pail is designed without ribs or crevices that can collect food or dirt, making them ideal for reuse. The Tear Strip/Tamper Evident lid allows for easy opening and re-closure.

PERFORMANCE SPECIFICATIONS

- No objection status for food contact applications from the Health Protection Branch in Canada and compliance for use in food contact applications by the Food and Drug Administration in the United States. Black pails excluded.

DIMENSIONS

Capacity		Rated	4L	Overflow	4.5L minimum
Fill Volume	With 222 Series Tear Strip Lid		4.2L		
Weight		Pail Only	163.0g ± 5.0g		
Dimensions		Overall Height	6.1"	Height With 222 Series Lid	6.18"
		Nominal Wall Thickness	0.050"		
		Top Diameter	8.235"	Bottom Diameter	7.335"

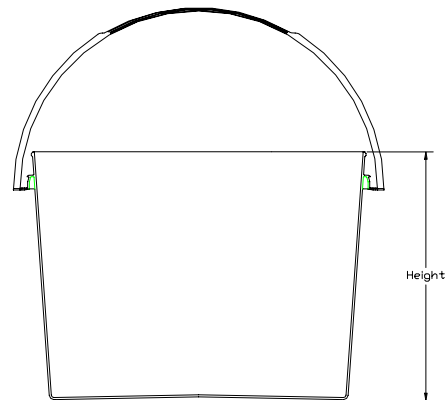
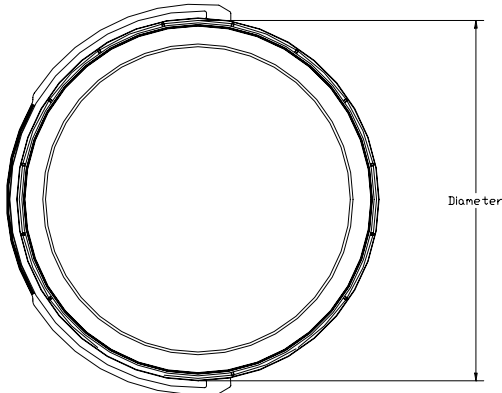

SPECIAL FEATURES

- Lid Recommendations The 222 series Tear Strip Lid, for use with solid, semi-solid, viscous and dry bulk food and household products.
- Decorating The pail is flame treated to improve adhesion of labels and inks. Reliance offers offset printing in 1 to 6 colours on a custom basis. Printable area is 4.0” high by 25” in average circumference
- Handle The handle is custom designed and made from high density polyethylene to aid in disposal and recycling.

FILLING AND STACKING RECOMMENDATIONS

- Compatibility of the pail and lid with fill product is the responsibility of the filler.
- Contents should not exceed 70°C (158°F) at time of fill.
- Filled containers should not be stacked and stored above 50°C (122°F).
- When affixing the lid to the pail, it is recommended that the centre of the lid be depressed to expel excess air from the container - commonly referred to as “burping”.
- Maximum stack height of 8 pails (four layers per pallet) when using 222 series lid, at a fill weight of 4.0 kg (8.8 lbs.) per pail.
- Palletization - 23 pails per layer in a 5x4x5x4x5 pattern on a standard 40” x 48” pallet. The use of double faced pallets is recommended, with stacks evenly spaced in such a manner that no pail overhangs the edges of the pallet. Pallet loads should be strapped and/or stretch wrapped to secure the load.

PACKAGING AND SHIPPING DATA

Quantity Per Pallet	368 pieces
Package Weight	132.2 lbs.
Shipping Dimensions (L x W x H)	42” x 38” x 26.5”
Shipping Volume (Cubic Feet)	24.5

Packaging includes top and bottom corrugate trays, secured with strapping and stretch wrap. Individual stacks of pails are enclosed in a plastic sleeve to protect them from outside sources of contamination.

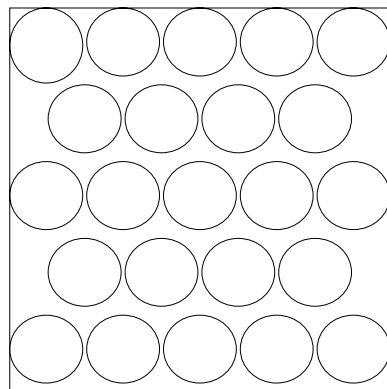

Top View of Pallet

WARRANTY

Reliance Products L.P. warrants product to meet the above specifications and to be free from defect in workmanship and materials at time of shipment. Liability is limited to the replacement cost of the containers purchased.

PRODUCT RANGE

Reliance Products L.P. has many decades of experience manufacturing a wide range of both injection and blow moulded plastic shipping containers, including:

Bottles	1L to 23L	Tighthead Containers	10L to 23L
Pails	4L to 23L	Collapsible Containers	10L to 25L

Call us for all of your related packaging needs