



10 Litre Rectangular Tight Head (Y1.8)

073 series

Mold Number(s): 976

A 10L, heavy duty rectangular tight head made of High Density Polyethylene. The package is ideal for use as a shipping container for a wide range of Chemicals and numerous general uses.

PERFORMANCE SPECIFICATIONS

- No objection status for food contact applications from the Health Protection Branch in Canada and compliance for use in food contact applications by the Food and Drug Administration in the United States. Black tight heads excluded.
- UN Classification for transportation or Group II or III liquid fill dangerous goods when used in conjunction with our specified 61mm cap. See sales specification SS-UN-018 for more information. Classification is good for land, sea and air transport. Compatibility of fill product with container is the responsibility of the filler.

DIMENSIONS

Capacity	Rated	10L	Overflow (to top of neck)	11.126L
Weight	Container Only	550g +/- 15		
Dimensions	Length	9.6"	Width	7.8"
	Height	12.034"		
Panel Dimensions (flat sections)	Sides W x H	6.75" x 7.625"	Front and Back W x H	5.25" x 7.625"
does not include flat corners			Circumference of Panel	30.70"

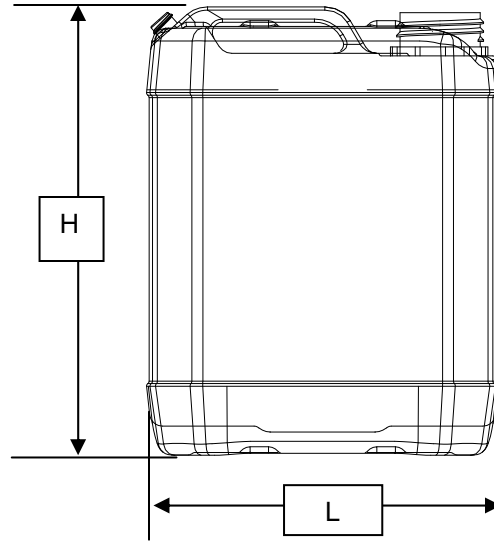
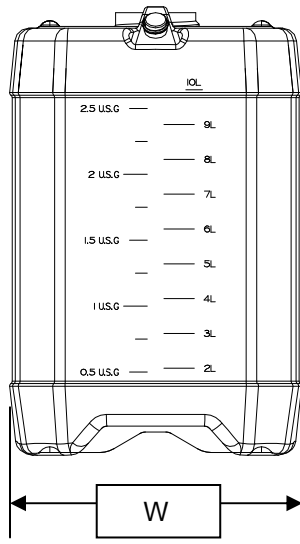

SPECIAL FEATURES

Neck Finish	Container is UN Registered with a 61mm neck finish.
Closures	Spigots and vented caps are available.
Venting	Available with or without 18mm vent at rear of container, capped or uncapped. End user may puncture vent to minimize glogging during pouring.
Stacking	Tight heads nest together to improve stability during storage.
Handle	A comfortable handle is moulded into the top of the tight head to aid in handling and for ease of pouring.
Palletization	This tighthead has been designed to make optimum use of a standard 40" x 48" pallet.

FILLING AND STACKING RECOMMENDATIONS

- Compatibility of the bottle with the fill product is the responsibility of the filler.
- Contents should not exceed 70°C (158°F) at time of fill.
- Filled containers should not be stacked and stored above 50°C (122°F).
- Maximum stack height of filled containers, based on contents of 10 kg (22 lbs.) per container, is 8 high. (four layers per pallet on two pallets).
- Containers should be arranged 24 per layer in a 4 x 6 pattern on a standard 40" x 48" pallet. The use of double-faced pallets is recommended, with stacks evenly spaced in such a manner such that no tight head overhangs the edge of the pallet. Pallet loads should be strapped and/or stretch wrapped to secure the load.

PACKAGING AND SHIPPING DATA

Quantity Per Pallet	120 pieces
Package Weight	195 lbs.
Shipping Dimensions (L x W x H)	47.37" x 45.75" x 48"
Shipping Volume (Cubic Feet)	59.76

Packaging includes top and bottom corrugate trays, secured with strapping and stretch wrap.

WARRANTY

Reliance Products L.P. warrants product to meet the above specifications and to be free from defect in workmanship and materials at time of shipment. *Liability is limited to the replacement cost of the containers purchased. Reliance Products LP does not test specific product packaging requirements and as such, customers are required to assure packaging meets the legal, environmental and containment needs of the product being packaged.*

PRODUCT RANGE

Reliance Products L.P. has many decades of experience manufacturing a wide range of both injection and blow moulded plastic shipping containers, including:

Bottles	1L to 23L	Tighthead Containers	10L to 23L
Pails	4L to 23L	Collapsible Containers	10L to 25L

[Call us for all of your related packaging needs](#)